

R / SG

for
Plate Heat Exchanger



Alkitronic[®]

designed for your needs

Applications

- These tools are ideally specialized for bolting connections on plate heat exchangers, e.g. in the food and beverage sector, the paper industry, and the chemical industry. They save much time when tightening and loosening plate packs where **perfect retention** and **absolute tightness** are essential.
- Reliable, low-wear operation due to **continuous rotation** when bolting with spindles or long threaded bolts.
- Depending on the application, electrical or pneumatic driven torque multipliers: torque up to 4,800 Nm.

Advantages

- **Load-free operation**, with short assembly time.
- **Fast simultaneous tightening** of large plate packs when using two or more torque multipliers diagonally.
- **alkitronic® RCL, CL2-SG** and battery driven torque multiplier **EA** with **fast gear for turning in** and simple, quick switching to power gear.

alkitronic® specials

- **Targeted types** for convenient working in **every tightening situation**: among other options between radial gearing (R) with high-performance worm drive; tangential gearing (SG) with highly efficient spur gear.
- **Long lifetime** due to extremely robust motor housing made of cast aluminum or break-proof polymer.

Specifications

Pneumatic driven models:

Prerequisites for best work with the indicated torques are an operating pressure of 2-7 bar at a volume flow of approx. 10-15 l/s. The torque accuracy depends on the stability of the supply system.

Electric driven models:

Universal AC input 100 V – 253 V, frequency 45 Hz – 66 Hz, power max. 2000 W, protection category I, **EFCip with protection class IP 54** (EF optional). **EA** models with two lithium-ion battery packs 18 V, 5.2 Ah, and battery charger.

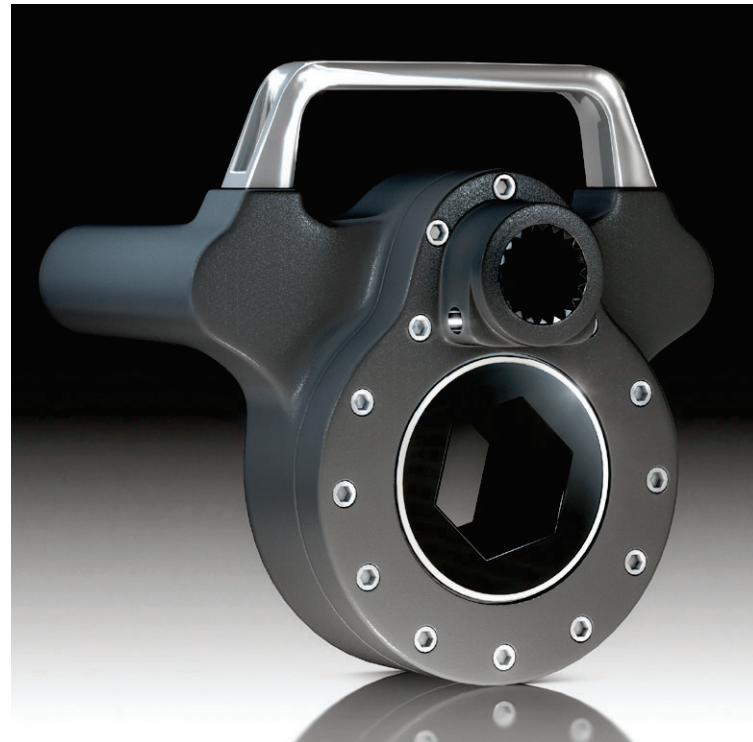

Product information Remote Control

alkitronic® CLV-R or CLV-SG

Model range with convenient remote control and individual pneumatic drive. When using several torque multipliers with radial (R) or tangential (SG) gearing, large packs can be tightened fast, simultaneously, and evenly.

- **Operation** of up to four torque multipliers **simultaneously**.
- Especially effective for multiple bolting connections and serial assemblies in **semi-automatic operations**.
- **Low-level sound emission** due to integrated sound reduction.

For highly efficient bolting connections with one or up to four **alkitronic® CLV** torque multipliers, preconfigured **alkitronic® Remote Systems** are already available.

FBL DUO for two **CLV** torque multiplier, **FBL QUATTRO** available on request.

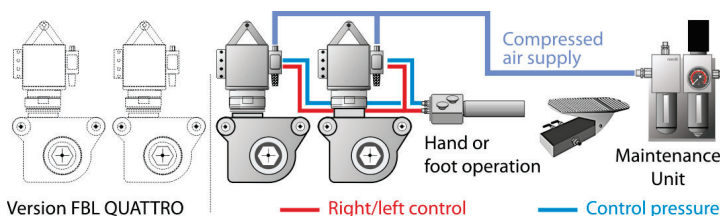
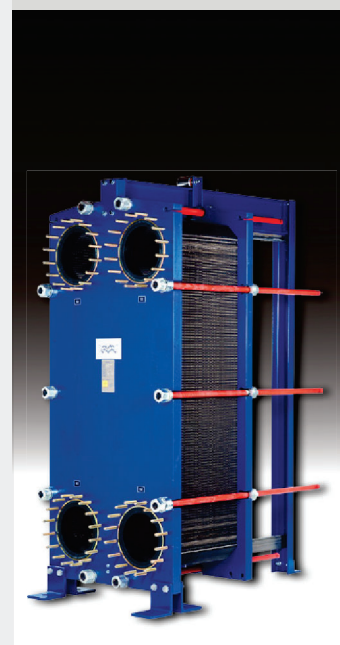

Image above:
alkitronic® RCL pneumatic torque multiplier in operation on a plate heat exchanger.

Image below: **alkitronic® CLV-R**

Image above:
alkitronic® CLS-SG in operation on a plate heat exchanger.

Image below:
PHE of Alfa Laval



Technical Data

alkitronic® Radial Gearing (R)

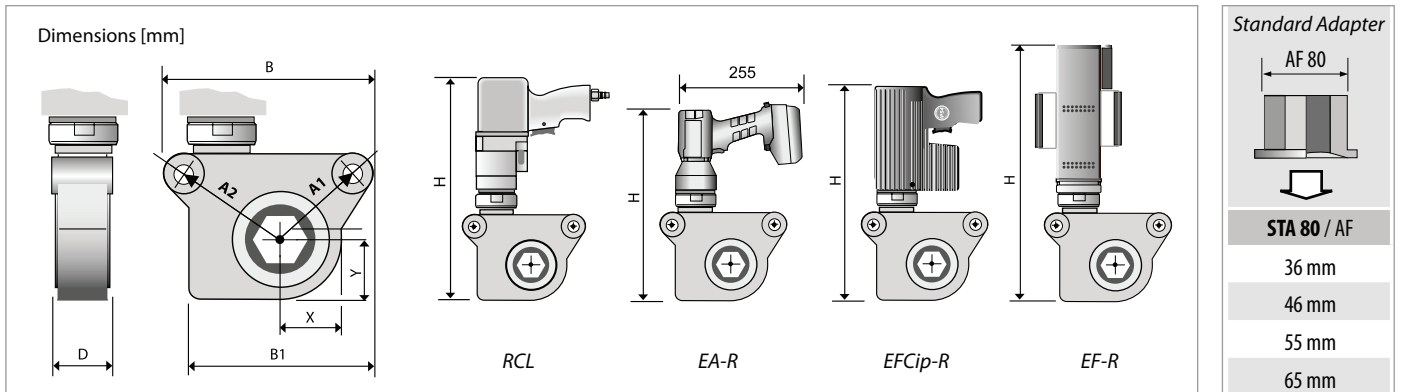

Radial Gearing Models	Pneumatic drive			Electric drive						
	RCL (2-Gear)			EA-R (2-Gear)		EFCip-R		EF-R		
Type	RCL 36	RCL 46	RCL 80	EA-R 36	EA-R 46	EFCip-R 36	EFCip-R 46	EFCip-R 80	EF-R 80	
Torque range 2nd gear (approx.)	Nm	160-470	250-780	670-1975	150-450	250-730	-	-	-	
Torque range 1st gear (approx.)	Nm	500-1500	800-2500	1645-4840	500-1500	750-2500	150-1590	250-2530	480-3840	560-3780
Width across flat (AF)	mm	36	46	80	36	46	36	46	80	80
Height (approx.)	H mm	400	435	450	400	450	385	425	475	600
Width (approx.)	B/B1 mm	230/190	252/215	325/240	230/190	252/215	230/190	252/215	325/240	325/240
Bolt distance (approx.)	A1/A2 mm	100/128	112/145	156/194	100/128	112/145	100/128	112/145	156/194	156/194
Dimensions (approx.)	X/Y mm	56/56	75/75	98/98	56/56	75/75	56/56	75/75	98/98	98/98
Dimension (approx.)	D mm	90	94	94	90	94	90	94	94	94
Weight (approx.)	kg	11	13.5	21	11	13.5	12	14.5	21	24.5
Idle speed 1st gear (approx.)	rpm	5	4.5	4	3	3	8	7	7	9
Idle speed 2nd gear (approx.)	rpm	15	14	12	10	10	-	-	-	-

When loosening a bolted connection, up to 20% higher torque may be required (loosening torque). We will gladly advise you in detail.

alkitronic® Tangential Gearing (SG)

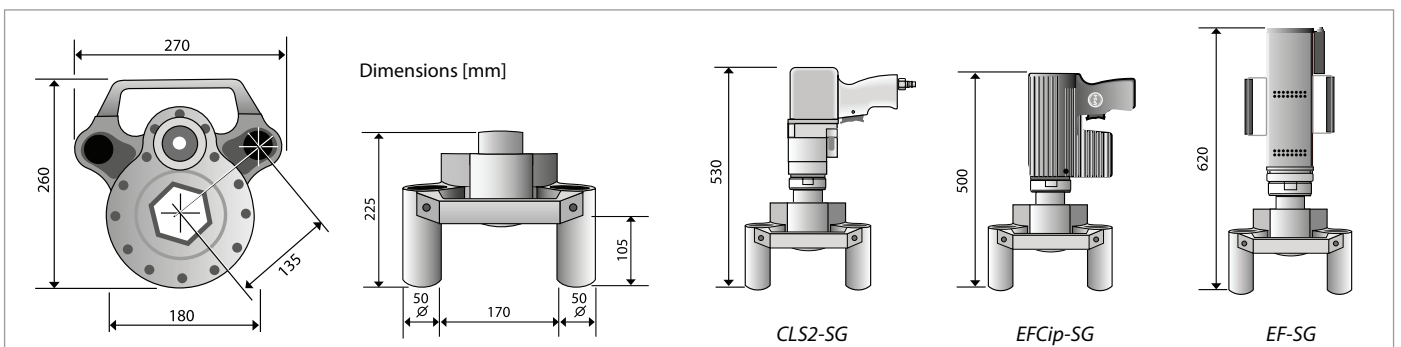

Tangential Gearing Models	Pneumatic drive		Electric drive	
	CLS2-SG (2-Gear)		EFCip-SG	EF-SG
Type	CLS2-SG 80		EFCip-SG 80	EF-SG 80
Torque range 2nd gear (approx.)	Nm	440-1330	-	-
Torque range 1st gear (approx.)	Nm	1400-3780	560-3780	560-3780
Width across flat (AF)	mm	80	80	80
Weight (approx.)	kg	17	19	22
Idle speed 1st gear (approx.)	rpm	3,5	6	10
Idle speed 2nd gear (approx.)	rpm	10	-	-

alkitronic® provides all drive technologies.

Extract from our product range:

✓ **ELECTRIC**



✓ **PNEUMATIC**



✓ **HYDRAULIC**



✓ **MANUAL**



alkitronic®

YOUR PLUS FOR MORE PERFORMANCE

Increased quality

Premium production
Highest quality materials
Long product life cycles
30 years experience in bolting technology
Made in Germany – international patents

Increased precision

Precise, customer-specific torques
High repeatability
Reliability in permanent operation
Dokumentation of tightening results
Automatic shut-off

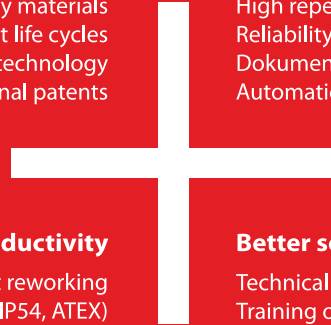

Increased productivity

Quicker tightening without reworking
No environmentally caused failures (IP54, ATEX)
High work safety
Easy to use: clear, simple instructions
Low maintenance and cost efficient

Better service

Technical advice on site
Training offers
Manufacturer's calibration and certification
Lifecycle support
Spare part and repair service

Please contact sales@appliedtorque.co.uk for further information

TORQUE POWER WORLDWIDE

alki TECHNIK GmbH
Development, Production and Distribution of Bolting Systems

Unterlettenweg 4 – 85051 Ingolstadt/Germany – fon +49 841 97499-0 – fax +49 841 97499-90
info@alkitronic.com – www.alkitronic.com