

# PA-Series, Air Hydraulic Pumps



▼ Shown from top to bottom: PA-1150, PA-133



## PA Series

Reservoir Capacity:

**36-80 in<sup>3</sup>**

Flow at Rated Pressure:

**8 in<sup>3</sup>/min.**

Maximum Operating Pressure:

**10,000 psi**



### PC-66 Reservoir Conversion Kit

Double the reservoir capacity of your existing PA-133 with this easy to install conversion kit.

- Rugged construction – built for long life and easy service
- Swivel coupling simplifies hydraulic connection and pump operation
- Three-position treadle provides cylinder advance, hold and retract operation
- PA-133 operates in all positions for increased versatility in use and mounting
- Base mounting slots provided on PA-133

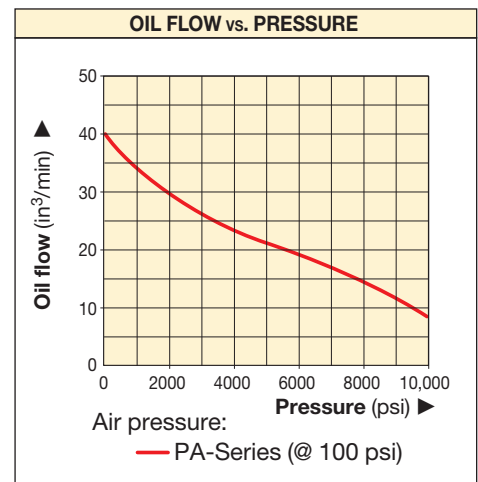

Dimensions shown in inches.

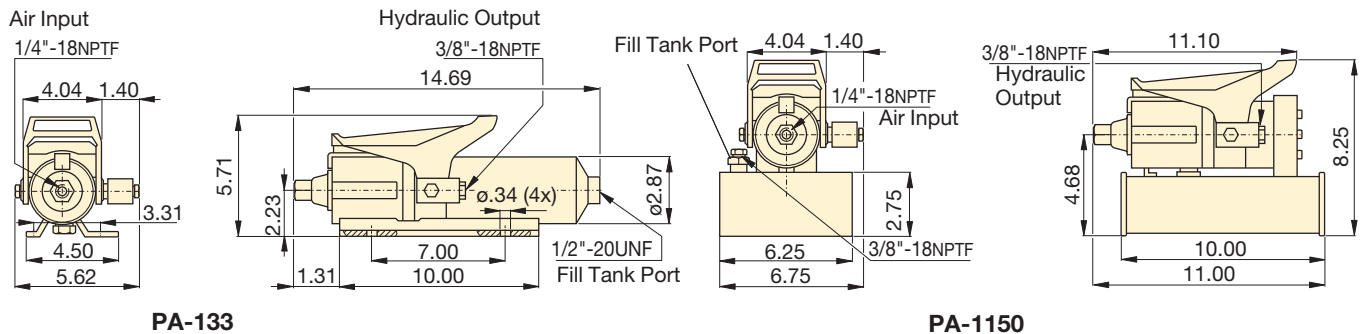

Used with Cylinder	Usable Oil Capacity (in <sup>3</sup> )	Model Number	Pressure Rating (psi)	Output Flow Rate (in <sup>3</sup> /min)		Valve Function	Air Pressure Range* (psi)	Air Consumption (scfm)	Sound Level (dBA)	Weight (lbs)
				No load	Load					
Single-acting	36	PA-133	10,000	40	8	Advance/Hold/Retract	60-120	9	85	12
	80	PA-1150	10,000	40	8	Advance/Hold/Retract	60-120	9	85	18

\* Recommended Regulator-Filter-Lubricator: RFL-102