

HCRL-Series, Double-Acting Lock Nut Cylinders

▼ HCRL-2006, HCRL-506

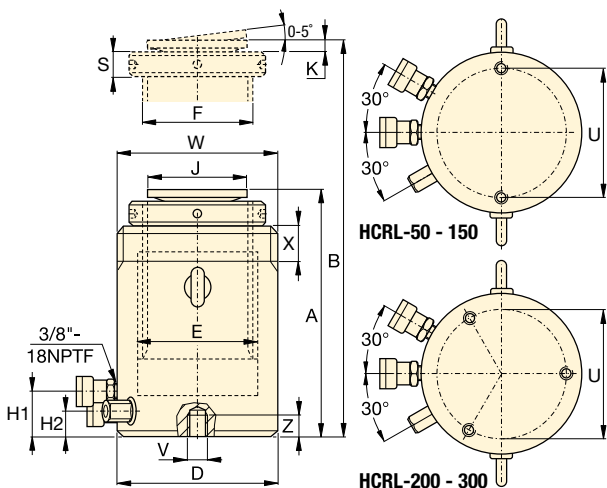

- Hydraulically controlled fast retraction
- Lock nut provides mechanical load holding for a safe work environment
- Designed to withstand up to 10% side-load of maximum capacity
- Integrated tilt saddle allows up to 5 degrees of misalignment
- Hardened surface resists side-loading and cyclic wear
- Weather protected, inside and out
- Replaceable bearings enclose the plunger external and internally for support
- Certified lifting eyes, base mounting holes and collar thread as standard
- Stop-ring to prevent plunger blow-out
- Low friction lock nut, to spin easily, save time and effort.



SELECTION CHART 50 - 300 TON HCRL-MODELS

For full product features see pages 40-41.

Cylinder Capacity *	Stroke *	Model Number	Maximum Cylinder Capacity at 700 bar ton (kN)	Cylinder Effective Area (cm ²)	Oil Capacity (cm ³)
50	150	HCRL-506	49 (479)	68,4	1025
	200	HCRL-508			1367
	250	HCRL-5010			1709
	300	HCRL-5012			2051
100	150	HCRL-1006	101 (990)	141,4	2121
	200	HCRL-1008			2827
	250	HCRL-10010			3534
	300	HCRL-10012			4241
150	150	HCRL-1506	153 (1501)	214,4	3216
	200	HCRL-1508			4288
	250	HCRL-15010			5360
	300	HCRL-15012			6432
200	150	HCRL-2006	204 (2001)	285,9	4288
	200	HCRL-2008			5718
	250	HCRL-20010			7147
	300	HCRL-20012			8577
250	150	HCRL-2506	251 (2463)	351,9	5278
	200	HCRL-2508			7037
	250	HCRL-25010			8796
	300	HCRL-25012			10.556
300	150	HCRL-3006	303 (2969)	424,1	6362
	200	HCRL-3008			8482
	250	HCRL-30010			10.603
	300	HCRL-30012			12.723

Collar Thread (mm)		
Model / Capacity ton	Thread Size W	Thread Length X
HCRL-50	M130 x 2	42
HCRL-100	M185 x 2	57
HCRL-150	M222 x 3	70
HCRL-200	M260 x 3	79
HCRL-250	M290 x 3	85
HCRL-300	M315 x 3	94

The collar thread length is designed for the full rated cylinder capacity.

Base Mounting Holes (mm)			
Model / Capacity ton	Bolt Circle U	Thread Size V	Minimum Thread Depth Z
HCRL-50	105	M12 x 1,75	22
HCRL-100	150	M12 x 1,75	22
HCRL-150	185	M12 x 1,75	22
HCRL-200	215	M12 x 1,75	22
HCRL-250	245	M12 x 1,75	22
HCRL-300	260	M16 x 2	25

* Up to 2000 ton and additional stroke lengths available on request.

Double-Acting Lock Nut Cylinders



Higher Capacities, Larger Strokes

The HCRL-Series Cylinders are available up to 2000 ton capacity and additional stroke lengths available on request.

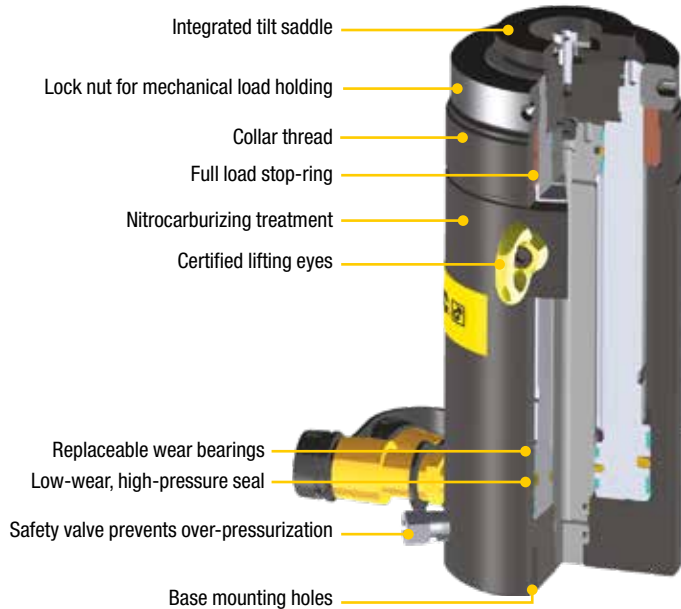

HCRL Series

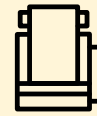

Capacity:

50 - 300 ton

Stroke:

150 - 300 mm

Maximum Operating Pressure:

700 bar



Synchronous Lifting Systems

Pumps for multiple lift-point capabilities. The economical **EVOB-Series** for basic applications and the multi-functional **EVO-Series** lifting system.

Page: **242**

Collapsed Height A (mm)	Extended Height B (mm)	Outside Diameter D (mm)	Cylinder Bore Diameter E (mm)	Plunger Diameter (threaded) F (mm)	Base to Advance Port H1 (mm)	Base to Retract Port H2 (mm)	Saddle Diameter J (mm)	Saddle Protrusion K (mm)	Lock Nut Height S (mm)	(kg)	Model Number
310	460	130	100	Tr 90 x 4	41	27	77	15	26	30	HCRL-506
377	577									36	HCRL-508
427	677									40	HCRL-5010
477	777									45	HCRL-5012
346	496	185	140	Tr 120 x 6	50	36	77	15	36	64	HCRL-1006
421	621									77	HCRL-1008
471	721									85	HCRL-10010
521	821									94	HCRL-10012
359	509	222	170	Tr 150 x 6	46	32	126	13	45	97	HCRL-1506
434	634									116	HCRL-1508
484	734									129	HCRL-15010
534	834									142	HCRL-15012
399	549	260	200	Tr 170 x 6	71	49	126	13	50	145	HCRL-2006
469	669									168	HCRL-2008
519	769									184	HCRL-20010
569	869									200	HCRL-20012
416	566	290	220	Tr 190 x 6	71	49	160	15	55	190	HCRL-2506
491	691									224	HCRL-2508
541	791									244	HCRL-25010
591	891									265	HCRL-25012
421	571	315	240	Tr 210 x 6	71	49	160	15	55	230	HCRL-3006
496	696									269	HCRL-3008
546	796									294	HCRL-30010
596	896									319	HCRL-30012