



**EC**

Electric Torque Multiplier



## Applications

- **alkitronic® EC-S / EC-A** electric torque multipliers from 75 to 6,530 Nm (55 to 4,815 ft.lbs).
- **Consistent torque accuracy** on all international power supplies 100 - 253 V / 45 - 66 Hz.
- **Precise shut-off** with on-site voltage-controlled portable generators.
- Models **alkitronic® EC-A** angled tools, low height for difficult access applications.

## Advantages

- **Safe interruption-free work** in any weather (moisture, rain) - thanks to protection class IP54.
- **Low running costs:** Low-wear, maintenance-free, brushless synchronous motor.
- **Permanent higher joint quality** by continuous rotation of the square drive.
- **Simple 1-finger trigger** operation for forward and reverse.
- **OLED-Display** anti-glare and high contrast - for perfect reading under all weather conditions.
- **Menu-guided intuitive operation**, with control and warning signals.
- **Ergonomic and comfortable operation:** The 360 degree rotating handle prevents reaction forces being transferred to the operator.

## alkitronic® specials

- **High-quality bolting**, according to torque/angle procedure.
- Highly innovative generation of electric torque multipliers with new sensorless control motor technology. Lower power consumption increases the service life of the electronic components.
- **Repeat shut-off accuracy  $\pm 2\%$**  for the same bolting application.
- **Precise reproduction of preselected torque** through intelligent, processor-controlled motor with automatic shut-off.
- **Longerservice life:** Low heat generation - thus highest reliability and almost no downtime.
- **Robust and long lasting:** Motor housing of cast aluminum.



## Specifications

### Bolting programs:

For user-specific applications, the manufacturer can activate optional modular software (**alkitronic® EC-S / EC-A** from serial number 712700).

<b>Software suite 1:</b>	Torque controlled bolting (pre-installed)
<b>Software suite 2:</b>	Torque/angle procedure for high-quality bolting connections
<b>Software suite 2 Premium:</b>	Torque/angle procedure with adjustable max. torque limit
<b>Software suite 3:</b>	Bolting with preset rotations and torque limit
<b>Software suite 4:</b>	Bolting parameters according to individual customer requirements
<b>Software suite 5:</b>	Bluetooth transmission via <b>alkitronic® APP</b> Documentation of the bolted joints (target-actual status, recording for each joint)

**Remote control of single or multiple torque multiplier can be manual or fully automated.**

**Special solution:** Preset torque increment according to customer's requirement (10 Nm / 10 ft.lbs min). All **alkitronic®** torque multipliers with CE-certification.

### Electrical data:

Universal AC input 100 V - 253 V, frequency 45 Hz - 66 Hz, power max. 1100 W, protection category I, protection class IP 54 (standard).



## Technical Data

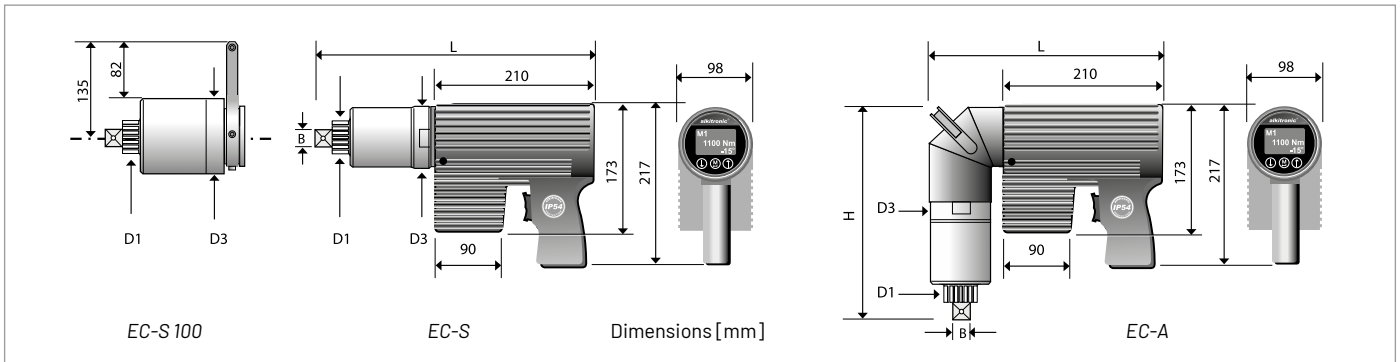

### Models EC-S

Type		EC-S 10	EC-S 20	EC-S 30	EC-S 35	EC-S 40	EC-S 50	EC-S 60	EC-S 65	EC-S 70	EC-S 80	EC-S 90	EC-S 100
Torque range (approx.)*	Nm	75-420	80-680	100-940	150-1300	150-1590	190-1870	250-2340	290-2930	350-3470	440-4400	500-5300	650-6530
	ft.lbs	55-305	60-500	75-690	110-960	110-1170	140-1380	185-1725	215-2160	260-2560	325-3245	370-3910	480-4815
Square drive	B	3/4"	3/4"	3/4"	3/4"	1"	1"	1"	1"	1 / 1 1/2"	1 1/2"	1 1/2"	1 1/2"
Diameter (approx.)	D <sub>1</sub> mm	41	41	41	41	54	54	54	54	72	72	72	72
Diameter (approx.)	D <sub>3</sub> mm	88	88	88	88	88	88	88	88	98	98	109	109
Length (approx.)	L mm	330	330	330	352	382	382	388	388	406	406	405	430
Weight without DMA (approx.)	kg	9	9	9	9	10	10	11	11	13	13	14.5	15.5
Idle speed	rpm	70	40	30	22	15	14	11	8	7	5	4	3

### Models EC-A

Type		EC-A 50	EC-A 60	EC-A 65	EC-A 70	EC-A 80	EC-A 90	EC-A 100
Torque range (approx.)*	Nm	190-1870	250-2340	290-2930	350-3470	440-4400	500-5300	650-6530
	ft.lbs	140-1340	185-1725	215-2135	260-2540	325-3205	370-3730	480-4800
Square drive	B	1"	1"	1"	1 / 1 1/2"	1 1/2"	1 1/2"	1 1/2"
Diameter (approx.)	D <sub>1</sub> mm	54	54	54	72	72	72	72
Diameter (approx.)	D <sub>3</sub> mm	88	88	88	98	98	109	109
Length (approx.)	L mm	310	310	310	318	318	326	315
Height (approx.)	H mm	300	305	305	315	315	345	350
Weight without DMA (approx.)	kg	14	14	14	16	16	17	18
Idle speed	rpm	14	11	8	7	5	4	3

\*) When loosening bolts, a higher torque (up to 20 %) may be necessary (release torque). We will be pleased to help you with your choice. \*\*) Torque reaction arm

### Display views

Software suite 1 (mode 1) and software suite 2 (mode 2)

Mode 1 / M1 (Standard)

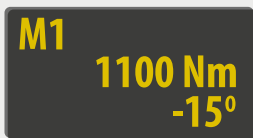

Bolting via torque. Automatic relief according to pre-set angle degrees.

Mode 2 / M2 (Option)

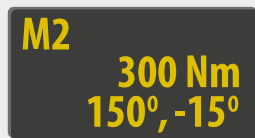

Torque/angle procedure for high-quality bolting connections. Display example of pre-torque, angle and loosening angle.

During the bolting process, the current torque value is shown in the display. Reaching the set value is indicated by an "OK". If the selected value cannot be achieved, the bolting operation is evaluated as "nOK".

### Scheme bolting programs

Torque controlled bolting mode 1

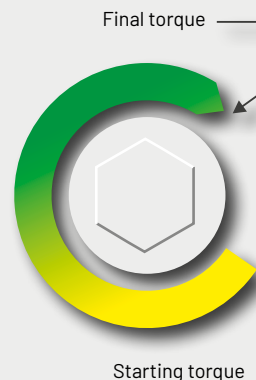

Torque/angle procedure mode 2

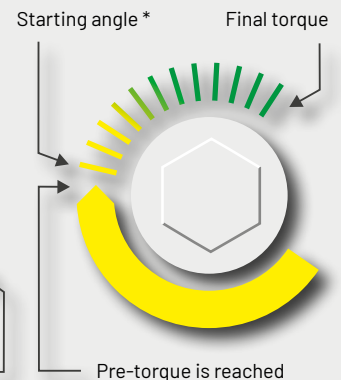

#### \* Information on rotational angle setting for torque/angle method:

- The angle of rotation is specified specifically for the bolting connection.
- The angle of rotation can be determined individually and easily with **alkitronic® HSD**. We will gladly provide you with detailed product information.



## YOUR PLUS FOR MORE PERFORMANCE

### Increased quality

- Premium production
- Highest quality materials
- Long product life cycles
- Experience in bolting technology since 1984
- Made in Germany – international patents

### Increased precision

- Precise, customer-specific torques
- High repeatability
- Reliability in permanent operation
- Documentation of tightening results
- Automatic shut-off

### Increased productivity

- Quicker tightening without reworking
- No environmentally caused failures (IP54, ATEX)
- High work safety
- Easy to use: clear, simple instructions
- Low maintenance and cost efficient

### Better service

- Technical advice on site
- Training offers
- Manufacturer's calibration and certification
- Lifecycle support
- Spare part and repair service

To know more of what we do, visit us at:  
Applied Torque Systems Ltd  
Unit S, Trecenydd Industrial Estate, Caerphilly, CF83 2RZ

Call us on:  
02920 888883

Email us:  
[sales@appliedtorque.co.uk](mailto:sales@appliedtorque.co.uk)

Or visit our website:  
[www.appliedtorque.co.uk](http://www.appliedtorque.co.uk)

### EXTRACT FROM OUR PRODUCT RANGE



**alkitronic XE-SERIES**  
THE ELECTRICS



**alkitronic XP-SERIES**  
THE PNEUMATICS

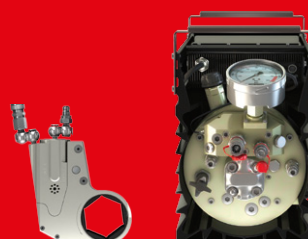

**alkitronic XH-SERIES**  
THE HYDRAULICS



**alkitronic XM-SERIES**  
THE MANUALS