

AMAX



AMAX HYDRAULIC PUMPS

torque

**STRENGTH
UNDER PRESSURE**

**APPLIED
TORQUE**
.co.uk

AMAX



PNEUMATIC HYDRAULIC TORQUE WRENCH PUMP THREE-STAGE PERFORMANCE

GET RELIABLE PORTABLE PERFORMANCE FROM A HEAVY DUTY HYDRAULIC TORQUE WRENCH PUMP. SET THE PRESSURE AND ACHIEVE THE TORQUE EVERY CYCLE.

TECHNICAL DATA

	AMAX
Reservoir Capacity (gal/litre)	2.2 / 8.4
Valve Style	Auto Retract
Air Motor Specification	4 HP / 2.9kW
Minimum Air Requirement	55 psi @ 35 CFM
Weight (lbs/kg)	60 / 27

MAX OIL FLOW

	AMAX	
Stage 1 (1000psi / 70bar)	610 cu.in / min	10.0 l / min
Stage 2 (4200psi / 300bar)	145 cu.in / min	2.4 l / min
Stage 3 (10,000psi / 700bar)	70 cu.in / min	1.1 l / min



DIMENSIONS

	AMAX
Length (in/mm)	16.8 / 427
Width (in/mm)	14.1 / 358
Height (in/mm)	17.6 / 447

RESERVOIR DIMENSIONS

	AMAX
Length (in/mm)	12.6 / 320
Width (in/mm)	9.4 / 239
Height (in/mm)	5.1 / 130

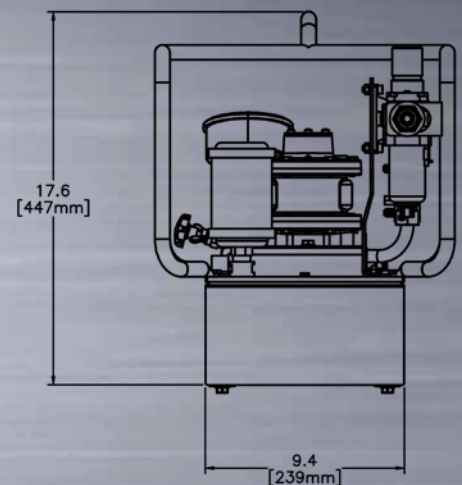
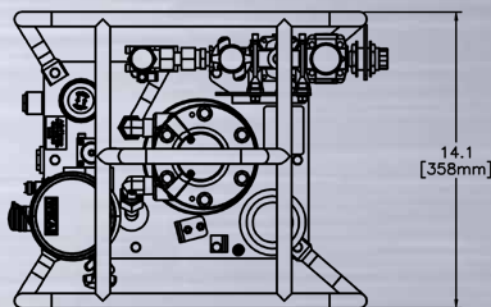
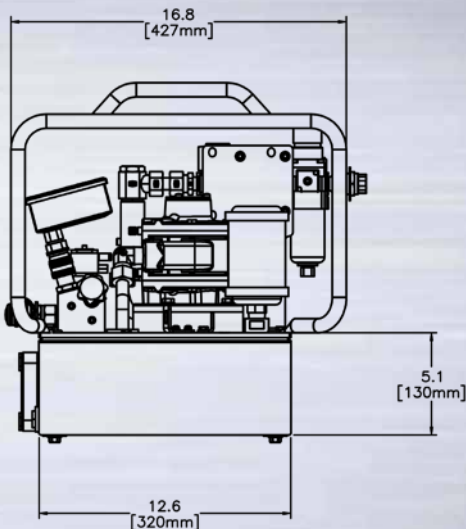

*All AMAX pumps fitted with an oil cooler & 15' pendant



TWIN LINE
HYDRAULIC HOSE



MULTI- PORT
MANIFOLD

* HYDRAULIC HOSE AND MULTI- PORT MANIFOLD SOLD SEPARATELY

Please contact sales@appliedtorque.co.uk for further information