

AMINI



AMINI HYDRAULIC PUMPS

torque

APPLIED
TORQUE
.co.uk

**PORTABLE
TORQUE POWER**

AMINI



PNEUMATIC HYDRAULIC TORQUE WRENCH PUMP TWO-STAGE PERFORMANCE

GET MAXIMUM PERFORMANCE FROM A MINIMUM WEIGHT HYDRAULIC TORQUE WRENCH PUMP. SET THE PRESSURE AND ACHIEVE THE TORQUE ALMOST ANYWHERE.

TECHNICAL DATA	AMINI	
Reservoir Capacity (gal/litre)	1.4 / 5.3	
Valve Style	Auto Retract	
Air Motor Specification	1.7 HP / 1.3 kW	
Minimum Air Requirement	55 psi @ 35 CFM	
Weight (lbs/kg)	38 / 17	

MAX OIL FLOW	AMINI	
Stage 1 (1000psi / 70bar)	400 cu.in / min	6.6 l / min
Stage 2 (10,000psi / 700bar)	40 cu.in / min	0.6 l / min



DIMENSIONS	AMINI	
Length (in/mm)	17.0 / 433	
Width (in/mm)	9.8 / 249	
Height (in/mm)	14.7 / 374	

RESERVOIR DIMENSIONS	AMINI	
Length (in/mm)	11.7 / 297	
Width (in/mm)	7.0 / 178	
Height (in/mm)	4.2 / 106	

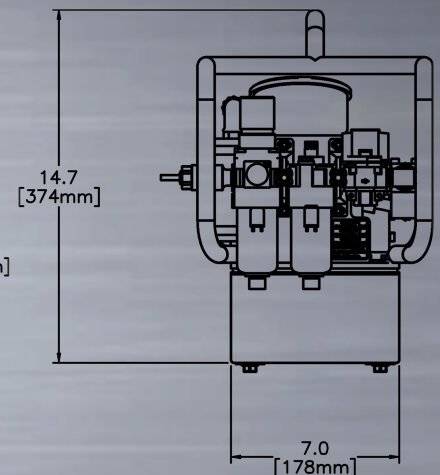
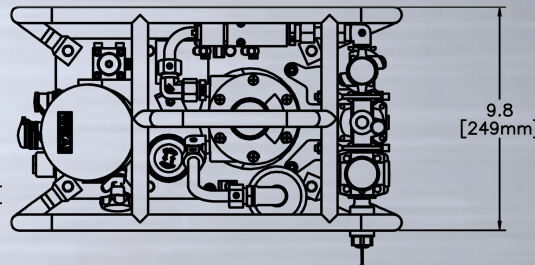
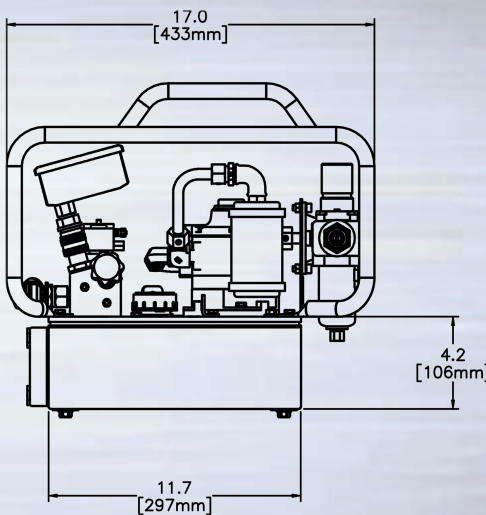

TWIN LINE
HYDRAULIC HOSE

MULTI- PORT
MANIFOLD



* HYDRAULIC HOSE AND MULTI- PORT MANIFOLD SOLD SEPARATELY

For Further information please contact sales@appliedtorque.co.uk