

▼ Shown from left to right: E291, E393, E494



- High-efficiency planetary gear sets achieve high output torque from low input torque
- Operator protected by anti-backlash device
- Torque multiplier accuracy $\pm 5\%$
- Reversible, tighten or loosen bolts
- Reaction bar or reaction plate style
- Angle-of-turn protractor standard on E300-Series models
- Reaction plate models offer increased versatility with reaction point locations
- E300 and E400-Series have replaceable shear drives, providing overload protection of internal power train
- One replacement shear drive is included with each E300 and E400-Series models.

Accurate, Efficient Torque Multiplication

When accurate make-up or break-out of stubborn fasteners requires high torque



Typical Torque Multiplier Applications

- Locomotives
- Power plants
- Pulp and paper mills
- Refineries
- Chemical plants
- Mining and construction
- Off-road equipment
- Shipyards
- Cranes.



◀ Enerpac Reaction Bar Torque Multiplier E393 used to manually torque bolts up to 4300 Nm.

▼ SELECTION CHART

Torque Multiplier Type	Nominal Torque Output		Model Number
	(Nm)	(Ft.lbs)	
Reaction Bar Multiplier	1015	750	E290PLUS
	1355	1000	E291
	1625	1200	E391
	2980	2200	E392
	4340	3200	E393
Reaction Plate Multiplier	2980	2200	E492
	4340	3200	E493
	6780	5000	E494
	10845	8000	E495



Manual Torque Multipliers

Enerpac manual torque multipliers provide efficient torque multiplication in wide clearance applications and when external power sources are not available.

Manual torque multipliers are used in most industrial, construction, and equipment maintenance applications. Hydraulic torque wrenches are better suited for tight tolerance, flange and repetitive bolting applications.

Use Reaction Bar Models:

- Where space is limited,
- Where multiple reaction points are available,
- when portability is desirable.

Use Reaction Plate Models:

- Above 4300 Nm output torque,
- On flanges and applications where neighbouring bolt or nut is available to react against
- When extreme reaction forces are generated.

E Series



Nominal Torque Output:

1015 - 10.845 Nm

Torque Ratio:

3:1 - 52:1

Output Ratio Accuracy:

± 5 %



CAUTION!

Never use impact air tools for power driving torque multipliers. Torque multiplier drive train damage will occur.

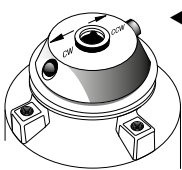

Selector Pawl

Models with anti-backlash protection have directional selector pawls. Set the pawl for clockwise or counter-clockwise rotation.

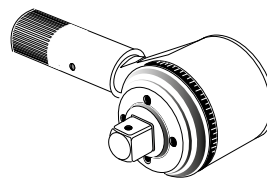

Angle-of-Turn Protractor

E391, E392 and E393 models include an angle-of-turn protractor (scale) to tighten fasteners using a "torque turn" method. Allows accurate measuring a specific number of degrees of rotation.

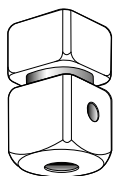

Shearable Square Drive

Provides overload protection on E300- and E400-series multiplier's power train by shearing when the rated capacity of the tool is exceeded. Internal shear pin prevents tool from falling off bolt.

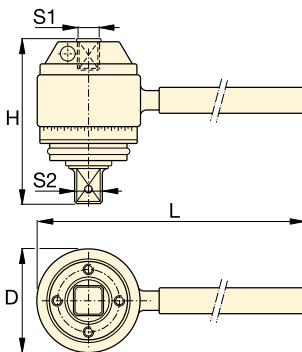

Reaction Bar Type ¹⁾

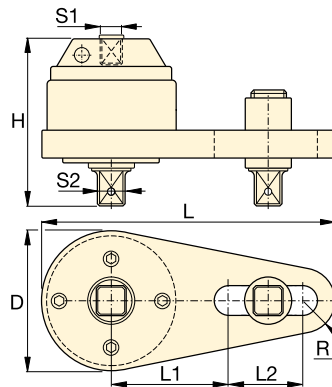

Reaction Plate Type ¹⁾



Hydraulic Torque Wrenches

Enerpac offers a complete range of square drive and hexagon cassette torque wrenches.

Page: 180



BSH-Series Sockets

Heavy-Duty Impact Sockets for power driven torqueing equipment.

Page: 184

Input Torque ²⁾	Torque Ratio	Input Female Square Drive	Output Male Square Drive		Over-load protection	Anti-Backlash	Dimensions (mm)						Model Number	
			S2 (inch)	Replaceable Shear Drive Model Nr.			D	H	L	L1	L2	R		
338 (Nm) / 250 (Ft.lbs)	3 : 1	1/2 (inch)	3/4 (inch)	-	No	No	71	84	218	-	-	-	1,8 (kg)	E290PLUS
451 (Nm) / 333 (Ft.lbs)	3 : 1	1/2 (inch)	3/4 (inch)	-	No	No	71	84	442	-	-	-	2,5 (kg)	E291
271 (Nm) / 200 (Ft.lbs)	6 : 1	1/2 (inch)	3/4 (inch)	E391SDK	Yes	No	100	102	498	-	-	-	6,3 (kg)	E391
219 (Nm) / 162 (Ft.lbs)	13,6 : 1	1/2 (inch)	1 (inch)	E392SDK	Yes	Yes	103	146	498	-	-	-	6,9 (kg)	E392
234 (Nm) / 173 (Ft.lbs)	18,5 : 1	1/2 (inch)	1 (inch)	E393SDK	Yes	Yes	103	165	498	-	-	-	8,3 (kg)	E393
219 (Nm) / 162 (Ft.lbs)	13,6 : 1	1/2 (inch)	1 (inch)	E392SDK	Yes	Yes	124	140	356	140	124	32	7,8 (kg)	E492
234 (Nm) / 173 (Ft.lbs)	18,5 : 1	1/2 (inch)	1 (inch)	E393SDK	Yes	Yes	124	163	356	140	124	32	10,6 (kg)	E493
256 (Nm) / 189 (Ft.lbs)	26,5 : 1	1/2 (inch)	1 1/2 (inch)	E494SDK	Yes	Yes	143	222	378	178	89	42	15,4 (kg)	E494
208 (Nm) / 154 (Ft.lbs)	52 : 1	1/2 (inch)	1 1/2 (inch)	E495SDK	Yes	Yes	148	273	386	178	89	48	22,8 (kg)	E495

¹⁾ E200 and E400-series do not have an Angle-of-Turn Protractor (scale).

²⁾ User must verify manual torque wrench accuracy prior to use to ensure accurate final output torque.