

THE EVOTORQUE® BATTERY TOOL (EBT) FEATURES A NEW BRUSHLESS MOTOR, DATA MEMORY AND DATA TRANSFER CAPABILITIES. NORBAR HAVE COMBINED THIS WITH THEIR RESPECTED GEARBOXES TO DELIVER A RANGE OF FAST, RELIABLE AND ACCURATE BATTERY TORQUE TOOLS.

Fast: EBT uses a powerful motor coupled with either a single speed or auto two speed gearbox for rapid joint completion times.

Durable: The industrial motor used by the EBT will keep going where most other battery tools will overheat.

Accurate: EBT is a transducer controlled battery powered torque tool designed for accurately applying torque to threaded fasteners. The unique 'intelligent joint sensing' technology continually measures the joint during tightening and when necessary, employs dynamic braking to avoid torque over-shoot due to motor inertia, consistently achieving highly accurate results of up to ±3% of setting.



The square drive is quickly and easily replaceable

Robust steel reaction supplied as standard

Bespoke reactions available on request

Handle and trigger designed for optimum comfort

18V, 5.0Ah battery and efficient motor give outstanding fastening performance per charge

High powered LED to illuminate application

OLED display ensures visibility in all conditions

Key Lock feature prevents unauthorised usage

Tried and tested gearbox design, reliable and proven over more than a decade

Brushless motor for low maintenance

Accuracy up to ±3%

180541 EBT
2,700 N-m Kit



EBT-72 Series

EBT-80 Series

EBT-92 Series

KEY FEATURES

- Tool is not constrained by power cable or hose, improving safety, convenience and versatility
- Multiple units of torque measurement, including N-m, lbf-ft and kgf-m
- Torque, Torque & Angle and Torque Audit modes available
- 'Torque Only' mode provides the user with 'Ease of Use' functionality aiding tool familiarity
- Display and on-board storage of final torque or torque and angle values
- 3,000 reading memory, time and date stamped
- Clear indication of successful joint application
- USB and Bluetooth® 4.0 data transfer (also called Bluetooth® Smart)
- Complimentary PC software 'EvoLog' for data management and tool configuration
- 12 user IDs can be downloaded to the tool and results can be stored against individual users
- 20 unique stand-alone targets plus 20 unique work group targets for each work group
- Results can be output in CSV (comma-separated values) format for users not able to use EvoLog
- Ability to produce and store real time graphs via EvoLog
- 'Usage' counter gives the ability to see the amount of times the tool has been used since the last reset
- 'Operation Direction' feature designed primarily for undoing bolts. When doing sequence tightening, it is possible to undo an incorrectly tightened bolt without interrupting the sequence.
- 'Turn Angle' option can be used to check if bolts have already been tightened in an assembly process
- Allows tool integration into third party control systems
- Maximum Audit Mode target angle (720°)
- Traceable calibration certificate for torque & angle provided as standard
- Available in single speed ideal for torque with angle control
- Auto two speed configurations available for rapid joint completion

Patent applied for

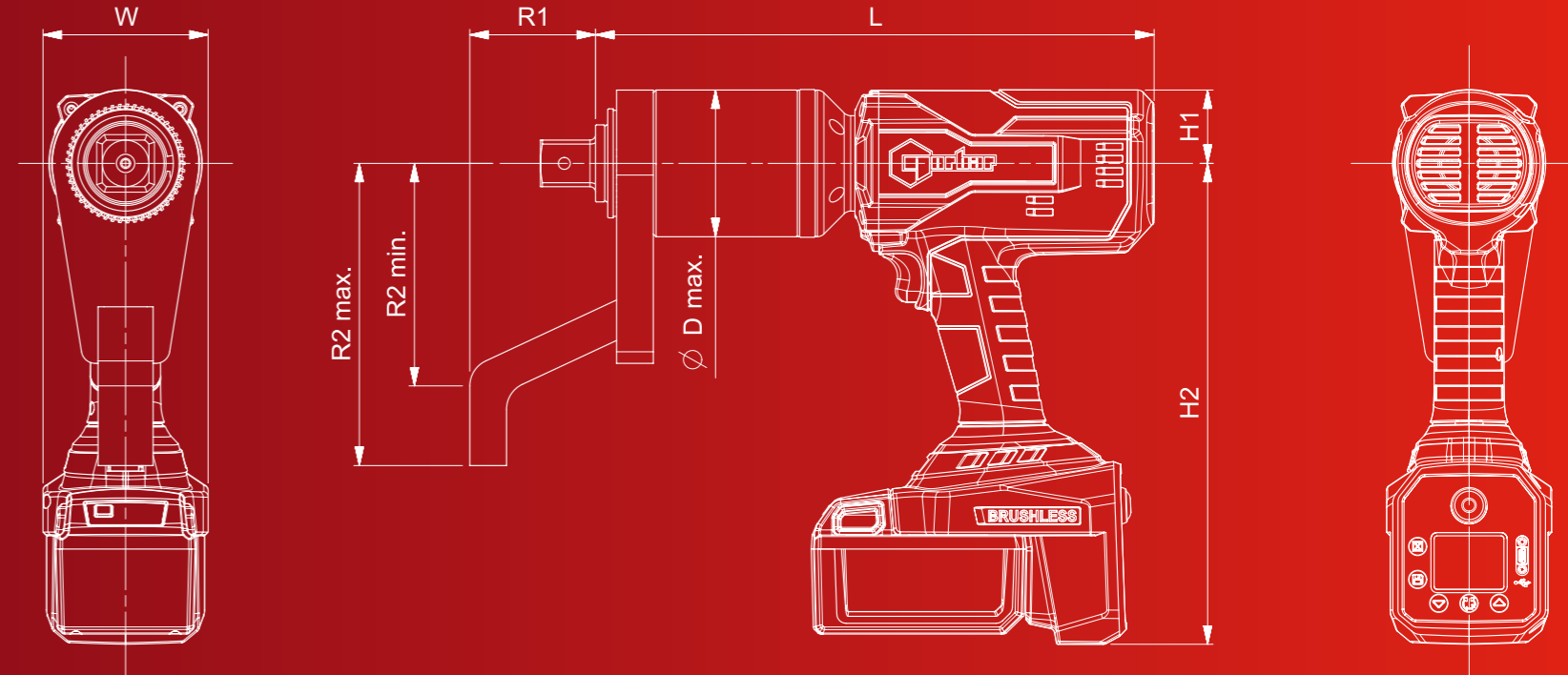

TECHNICAL SPECIFICATION

KIT PART NUMBER	BARE PART NUMBER	MODEL	SQUARE DRIVE	CALIBRATED RANGE		DIMENSIONS (mm)								TOOL WEIGHT (kg) *	REACTION WEIGHT (kg)	OUTPUT SPEED (rpm)
				N-m	lbf-ft	Ø D max	H1	H2	L	R1	R2 min	R2 max	W			
180445	180446	EBT-72-1350	½" & 1"	200 - 1,350	150 - 1,000	72	40	262	298	76	124	167	90	5.7	1.4	6.5
180469	180470	EBT-72-1350 Auto 2 Speed	½" & 1"	338 - 1,350	250 - 1,000	72	40	262	317	76	124	167	90	5.9	1.4	32
180541	180542	EBT-80-2700	1"	400 - 2,700	295 - 2,000	80	40	262	298	76	124	167	90	5.9	1.4	3.3
180565	180566	EBT-80-2700 Auto 2 Speed	1"	676 - 2,700	499 - 2,000	80	40	262	333	76	124	167	90	6.8	1.4	13
180637	180638	EBT-92-4000	1"	800 - 4,000	590 - 2,950	92	40	262	352	70	125	175	90	7.9	2.5	2.3
180661	180662	EBT-92-4000 Auto 2 Speed	1"	1,000 - 4,000	738 - 2,950	92	40	262	387	70	125	175	90	8.3	2.5	9.5

NOTE: Kit versions come with tool, 2 batteries, charger and a secondary handle in a carry case. Bare tools come without batteries, charger or a secondary handle in a cardboard box.

* Tool weight excludes both reaction and battery. The battery weighs 0.8 kg.

