

# EMINI



EMINI HYDRAULIC PUMPS

*torque*

**APPLIED**  
**TORQUE**  
.co.uk

**PORTABLE  
TORQUE POWER**

# EMINI

## ELECTRIC HYDRAULIC TORQUE WRENCH PUMP



# TWO-STAGE PERFORMANCE

GET RELIABLE PORTABLE PERFORMANCE FROM A HEAVY DUTY HYDRAULIC TORQUE WRENCH PUMP. SET THE PRESSURE AND ACHIEVE THE TORQUE ALMOST ANYWHERE.

### TECHNICAL DATA

### EMINI -115V/230V

Reservoir Capacity (gal/litre)	1.4 / 5.3	
Valve Style	Auto Retract	
Motor Specification	0.8 hp / 0.6 kW	
Weight (lbs/kg)	39 / 17.7	

### MAX OIL FLOW

### EMINI-115V/230V

Stage 1 (1000psi / 70bar)	310 cu.in / min	5.1 l / min
Stage 2 (10,000psi / 700bar)	31 cu.in / min	0.5 l / min



### DIMENSIONS

### EMINI-115V/230V

Length (in/mm)	17 / 432	
Width (in/mm)	9.8 / 249	
Height (in/mm)	14.7 / 373	

### RESERVOIR DIMENSIONS

### EMINI-115V/230V

Length (in/mm)	11.7 / 297	
Width (in/mm)	7.0 / 178	
Height (in/mm)	4.6 / 117	

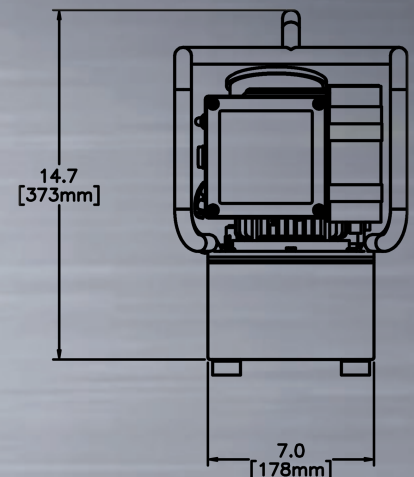
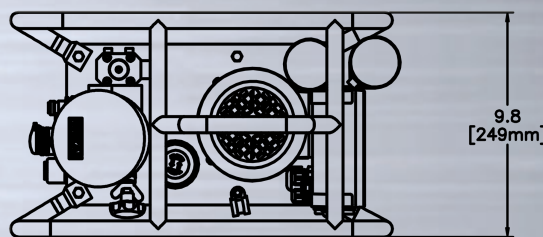
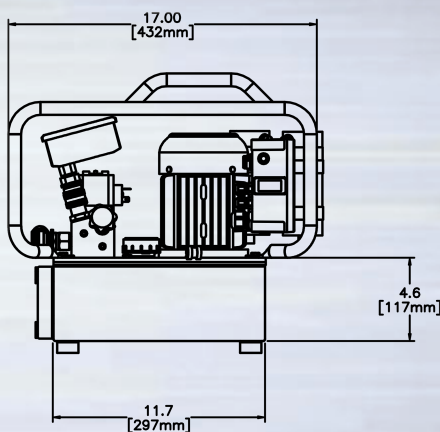

TWIN LINE  
HYDRAULIC HOSE

MULTI- PORT  
MANIFOLD



\* HYDRAULIC HOSE AND MULTI- PORT MANIFOLD SOLD SEPARATELY

For further information please email [sales@appliedtorque.co.uk](mailto:sales@appliedtorque.co.uk)