

▼ Shown: XA11G



Control and Ergonomics



Optional Pressure Gauge

Integrated gauge with calibrated scale reading in psi, bar and MPa for actual pressure reading.



Optional 4-Way 3-Position Valve

For powering double-acting hydraulic cylinders and tools.



Optional 1/2 Gallon Reservoir

Double oil capacity for powering larger hydraulic cylinders and tools.



Pedal Safety Guard

Customer installed frame protects both pedals against accidental activation.

Order model number ¹⁾

XPG1



"Joy-stick" Lever Kit

Customer installed set of handles for manual operation of both pedals.

Order model number ¹⁾

XLK1



Hydraulic Swivel Connector

Customer installed swivel connector for optimal orientation of the hydraulic hose.

Order model number ¹⁾

XSC1

¹⁾ Accessories must be ordered separately.

- Higher oil flow for increased productivity
- Variable oil flow and fine metering for precise control
- Ergonomic design for less operator fatigue
- Closed hydraulic system prevents contamination and allows pump usage in any position
- Pedal lock function for retract position
- External adjustable pressure setting valve
- ATEX Certified.* Includes ground screw for explosion protection

* See explanation of ATEX Certification in "Yellow Pages."



▼ Easily operated by foot. No need to fully lift up foot - rest body weight on heel, resulting in a hands-free and stable working position.





PRODUCTION APPLICATION

XA11 pump is used with a 13-ton hollow cylinder to compress and position diesel engine valve springs.

The operator benefits from the fine metering capabilities to apply the mandatory precise stroke and force.

XA Series

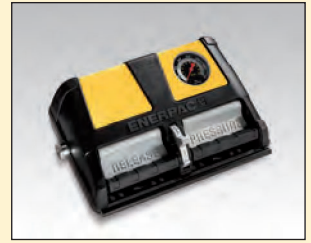

Reservoir Capacity:
61-122 in³

Flow at Rated Pressure:
15 in³/min.

Air Consumption:
10-35 scfm

Maximum Operating Pressure:
10,000 psi

▼ XA-SERIES PERFORMANCE CHART

Maximum Pressure (psi)	Output Flow Rate (in ³ /min)		Pump Series	Valve Function	Dynamic Air Pressure (psi)
	No load	Load			
10,000	120	15	XA1	Advance/Hold/Retract	30-125

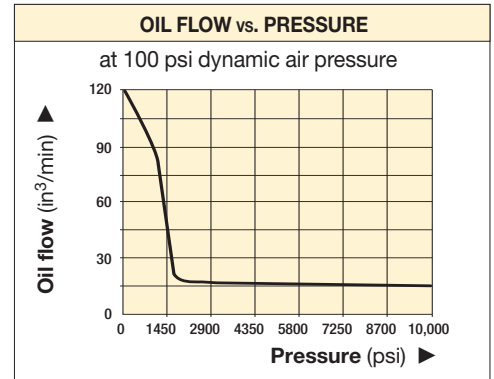
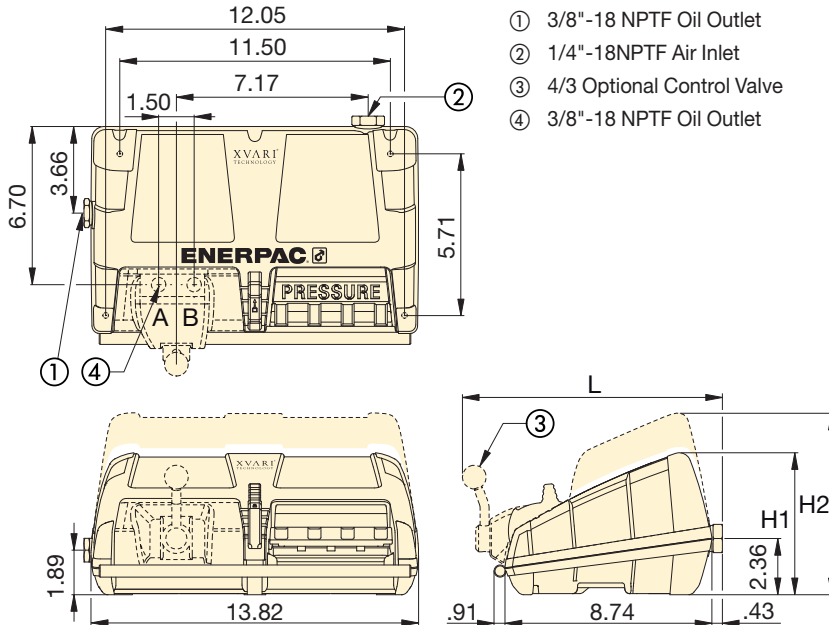

Regulator-Filter-Lubricator

Recommended for use with all XA-Series Air pumps. Provides clean, lubricated air and allows for air pressure adjustment.

Order model number ¹⁾

RFL102

▼ SELECTION CHART

For Use With Cylinder Tool	Usable Oil Capacity (in ³)	Model No. ¹⁾	Pressure Gauge	3-Way, 3-Position Valve	4-Way, 3-Position Valve	Dimensions (in)			Weight (lbs)
						H1	H2	L	
Single-acting	61	XA11 ²⁾	–	•	–	5.98	–	–	19.0
	122	XA12 ²⁾	–	•	–	–	6.69	–	22.4
Single-acting	61	XA11G	•	•	–	5.98	–	–	19.4
	122	XA12G	•	•	–	–	6.69	–	22.9
Double-acting	61	XA11V	–	–	•	5.98	–	10.98	22.3
	122	XA12V	–	–	•	–	6.69	10.98	25.7
Double-acting	61	XA11VG	•	–	•	5.98	–	10.98	22.7
	122	XA12VG	•	–	•	–	6.69	10.98	26.2

¹⁾ High-flow coupler CR400 and accessories must be ordered separately.

²⁾ Available as cylinder pump set, see page 52.